

Experimental Investigations based on a Demonstrator Unit to analyze the Combustion Process of a Nitrous Oxide/Ethene Premixed Green Bipropellant

Lukas Werling

German Aerospace Center (DLR), Institute of Space Propulsion Business or Academic Affiliation

Head Facilities Group

Im Langen Grund, 74239, Hardthausen, Germany

Lukas.Werling@dlr.de

Nikolaos Perakis (German Aerospace Center), Benjamin Hochheimer (German Aerospace Center), Helmut Ciezki (German Aerospace Center), Stefan Schlechtriem (German Aerospace Center)

ABSTRACT

Since the 1960s hydrazine is used as a monopropellant to power rockets, satellites or planetary probes. Due to hydrazine's high toxicity and the request for safer and cheaper propellants with comparable performance, several so called "Green Propellants" are under investigation. The most prospective candidates seem to be energetic ionic liquids (HAN-based or ADN-based), hydrogen peroxide or nitrous oxide fuel blends.

Aside with ADN-based monopropellants the German Aerospace Center's Institute of Space Propulsion in Lampoldshausen is carrying out research on a nitrous oxide/ethene premixed bipropellant. The benefits of this propellant (I_{sp} about 300 s and low toxicity) are facing the challenges like the need for a proper flashback-arrestor and the high combustion temperature (up to 3300 K). The combustion, injection and ignition behavior of the propellant are investigated experimentally using a combustor unit. Calculations with NASA CEA and RPA were performed to derive possible operation points for the combustor as well as for later use in vacuum thrusters. Furthermore the components of the combustor, the test bench as well as results of the first test runs are presented in this paper.

1 NOMENCLATURE

C^*	= Characteristic Velocity [m/s]
EILs	= Energetic Ionic Liquids
FOI	= Swedish Defence Research Agency (Totalförsvarets forskningsinstitut)
I_{sp}	= Specific impulse (by weight) [s]
NASA CEA	= Chemical Equilibrium with Applications, NASA Rocket Performance Tool [2]
P_c	= Combustion chamber pressure [MPa]
ROF	= Ratio of the mass flows: oxidizer/fuel
RPA	= Rocket Performance Analysis Tool [1]
ϵ	= Expansion Ratio (nozzle exit area/nozzle throat area)

2 INTRODUCTION

Hydrazine and its derivatives are used as propellants in a wide range of space applications, e.g. in satellite attitude control, planetary mission maneuvers or orbital maneuvers [3]–[5]. The long history of hydrazine thrusters led to a wide range of engines, operating for many years in space. One notable example are the thrusters of the Voyager 1 probe still working after more than 33 years [6]. In addition the I_{sp} of hydrazine is sufficient for many applications. Further advantages compared to other propellants

are the absence of explosion hazards and the possibility to form a hypergolic mixture with dinitrogen tetroxide. The named benefits are facing several significant disadvantages. One main problem is hydrazine's high toxicity. It is carcinogenic and has a non-negligible vapor pressure. Therefore extensive safety regulations have to be respected. This finally results in increasing handling efforts as well as transportation costs. The expenses and safety requirements lead to less flexibility during fueling, preparing or testing a spacecraft. Due to hydrazine's high toxicity it was added to the candidate list of substances of very high concern (SVHC) in the context of Europe's REACH (Registration Evaluation Authorization and Restriction of Chemicals)-Regulation [7]. This has caused increased concern over future restrictions on the production and use of hydrazine. As a consequence of the mentioned disadvantages several "Green Propellants" for replacing hydrazine as a monopropellant are under investigation. The following subsection will name some recent alternatives, their advantages and disadvantages. Additionally some general features of the propellants will be given.

2.1 Alternatives to Hydrazine, "Green Propellants"

Energetic Ionic Liquids (EILs)

A group of very prospective candidates for hydrazine replacement are the so called energetic ionic liquids. Ionic liquids used for propulsion applications mainly consist of an energetic salt, a solvent like water and a fuel. The energetic salt is dissolved in water and a fuel and therefore forms an ionic liquid. Characteristic for ionic liquids is their low vapor pressure and their liquid state at ambient conditions [8]. Due to their components and the low vapor pressure, the health hazards are significantly lower than the health concerns dealing with hydrazine. Two main kinds of propellants are studied at the moment: ADN (Ammonium dinitramide)-based propellants and HAN (Hydroxylammonium nitrate)-based propellants. In the US the HAN-based AF-M315E propellant is under investigation and should be tested in space soon [9]. In the EU, invented by ECAPS respectively FOI, the ADN based propellants LMP-103S and FLP-106 are the focus of research activities [10]–[12]. LMP-103S is the only mixture which has been tested in space [8]. In addition to the advantages of lower toxicity than hydrazine, the ionic liquids offer a higher I_{sp} as well as a higher density I_{sp} . Furthermore by adjusting the water content of the mixture, the combustion temperature could be adapted which leads to more flexibility in choosing thruster materials and eliminates the need for an active cooling system.

Nitrous Oxide Fuel Blends (NOFB, NICEMs)

Another promising class of Green Propellants are the so called nitrous oxide fuel blends. Those fuel blends consist of nitrous oxide mixed with different hydrocarbons (e.g. C_2H_2 , C_2H_4 , or C_2H_6). To obtain the propellant, the single components are pressurized, cooled (down to about 220K) and mixed [13]. Characteristic for the blends are the high vapor pressures, which could enable self-pressurization of the whole propulsion system. On the one hand the high reactivity of the mixture offers the opportunity of a simple ignition system (e.g. a spark plug) [14]. On the other hand, the whole propulsion system needs a proper flashback arrestor to avoid flame propagation into the tank during all possible operation modes. Another challenging aspect is the high combustion temperature of those premixed propellants. A reliable cooling system must be established to handle combustion temperatures up to 3500 K [14]. A significant advantage of the nitrous oxide fuel blends is their high I_{sp} . Depending on the mixture composition, an increase of 100s compared to hydrazine is possible. Furthermore only minor health hazards arise, dealing with those propellant mixtures. So cheaper and easier handling seems to be possible.

Hydrogen Peroxide (H_2O_2)

Hydrogen peroxide is a third group of green propellants currently under investigation. Typically the concentration for H_2O_2 used as a rocket propellant is in between 80-90 %. Those concentrations are

needed to achieve an I_{sp} of about 150 s, which is quite low compared to hydrazine. Characteristic for hydrogen peroxide is its decomposition to O_2 and H_2O with time. Due to its reactivity, compatible materials have to be selected carefully. Advantages of H_2O_2 are its benign effect on environment and the low health hazards. Furthermore a catalytic decomposition is possible and the combustion temperature is significant lower than that of other green propellant candidates. The explosive hazards coming along with the use of hydrogen peroxide have not been thoroughly investigated [15], [16]. Furthermore H_2O_2 was under investigation to be used as an attitude control and propellant settling system for the Ariane 5ME [17].

2.2 Comparison of “Green Propellant” to Hydrazine

The following table shows several main attributes of the previously named propellants. Due to different operation points and restrictions for the calculations, the corresponding references are named. The health hazards as well as the costs were estimated with respect to the properties of the single components. As an example for the costs, 1kg of ADN is 1000 €, while 1 kg of 85 % H_2O_2 is about 6 €.

Table 1: Characteristic parameters for several monopropellants (adapted from [18])

Propellant	Theoretical Vacuum I_{sp} [s]	Combustion Temperature [K]	Health hazards	Estimated costs
Hydrazine	245 [3]	1227 [5]	high	medium
AF-M315E	257 [9]	2173 [5]	medium	medium
LMP-103S	244-255 [8], [19]	1873 [20]	low	high
FLP-106	255-261 [8], [21], [22]	1910 [8]	low	high
H_2O_2 (87.5%)	144 [23]	968 [5]	low	low
NOFBX™	325-345 [14]	3473 [14]	low	low
N_2O & C_2H_4	302*	3250*	low	low

* Calculations with NASA CEA, ROF=6, $P_c=1MPa$, Frozen at throat

The Institute of Space Propulsion of the German Aerospace Center (DLR) is carrying out research in two groups of green propellants: ADN based monopropellants (e.g. in the EU-funded RHEFORM Horizon 2020 project) and in the field of nitrous oxide fuel blends. The next paragraph shows general performance calculations of a nitrous oxide/ethene premixed monopropellant. This section is followed by a description of the test bench for conducting combustion tests with the N_2O/C_2H_4 mixture and a paragraph with several test results.

3 THEORETICAL PERFORMANCE ANALYSIS

To examine possible I_{sp} values, combustion temperatures and to derive operating points for the chosen N_2O/C_2H_4 mixture, calculations with NASA CEA [2] and RPA V1.2 lite [1] were conducted. For all calculations the chamber pressure was fixed to 1MPa. The nozzle expansion ratio was set equal to 1 (cut at nozzle throat) or 40 and the chemical reaction model was altered between “frozen at throat” and “equilibrium”. In each diagram the performance parameters for vacuum expansion and expansion at sea level are shown. The expansion ratio of 40 was chosen with regard to later vacuum thrusters, while the values for $\epsilon = 1$ were calculated to establish comparability to conducted combustion tests with truncated nozzles. In the following figures, the values obtained by NASA CEA are colored black, the RPA values are presented in red. Stoichiometric reaction of both substances takes place at an ROF of about 9.4.

3.1 Temperature and C* Values

Figure 1 shows the resulting combustion temperatures and C* values of N₂O/C₂H₄ mixtures with different oxidizer to fuel ratios. The calculations for ROF values from 1 to 15 were conducted using NASA CEA with a Matlab routine and the “nested analysis” option of RPA lite. The chamber pressure used for the calculations was 1MPa. The solid lines represent the combustion temperature, the dashed lines the C* values. As Figure 1 shows, the maximum temperatures of 3200 to 3300 K were calculated in both programs at a ROF of about 7.5.

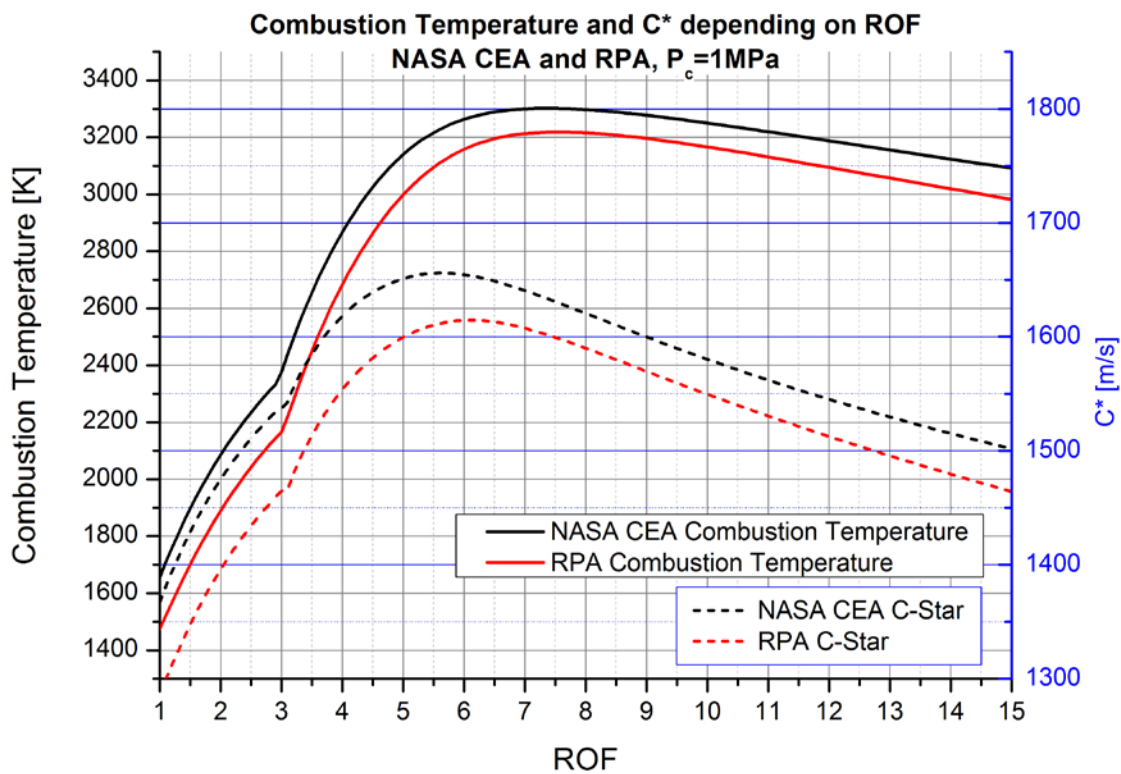

Figure 1: Combustion Temperatures and C* values of N₂O/C₂H₄ mixtures

At this point the C* values are in between 1600 m/s and 1630 m/s, while the maximum C* values are obtained at an ROF of about 5.5 to 6. The distinct change in gradients at a ROF of about 3 might occur due to a change of the reaction paths or by reason of species production. For example the output files of NASA CEA show formation of solid carbon (soot) for ROF values smaller than 3.

3.2 I_{sp} Values at vacuum and ambient Conditions

In Figure 2 the I_{sp} values obtained by NASA CEA and RPA for expansion ratio of 1 at ambient pressure and the corresponding values for vacuum expansion are shown. The chamber pressure was kept to 1 MPa. The maximum I_{sp} for vacuum expansion could be reached with an ROF of about 5.5 to 6. For an expansion at ambient conditions, an I_{sp} of 115-123 s could be expected.

Figure 3 indicates the corresponding I_{sp} values for an expansion ratio of 40 assuming frozen reactions at nozzle throat. The maximum values for vacuum I_{sp} are located at a mixture ratio of about 5.75 (302 s) using CEA, and 6.5 (299 s) when using RPA. There are no CEA results for mixture ratios smaller than 3, due to a divergence error during calculation. This might be caused by low gas temperatures and an equivalent low pressure at the exit.

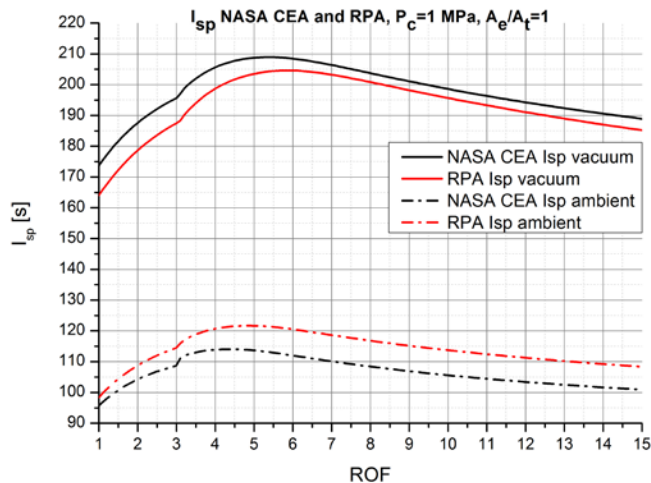

Figure 3: Ambient and vacuum I_{sp} with truncated nozzle ($\epsilon=1$)

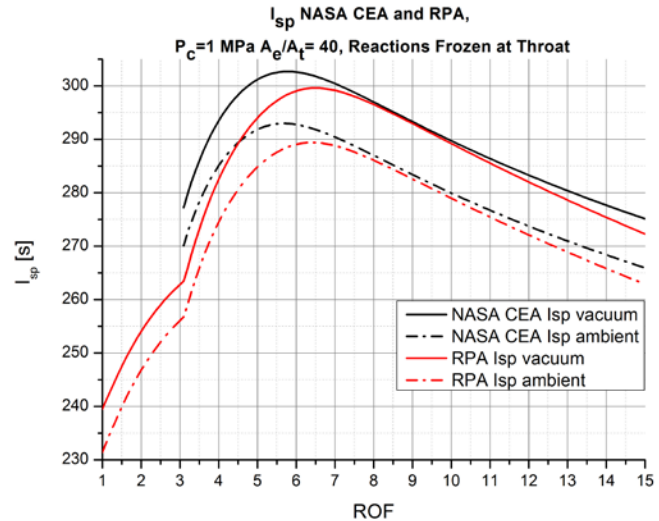

Figure 2: Ambient and vacuum I_{sp} , $\epsilon=40$, frozen reactions at throat

Additionally, calculations with equilibrium reactions were conducted. The results of those calculations are shown in Figure 4. Under these conditions the highest I_{sp} values could be reached. NASA CEA predicts a maximum vacuum I_{sp} of about 319 s for an ROF of 8.25, while RPA gives an I_{sp} of 312 s at a mixture ratio of 8.75. The parameters and values obtained by the shown calculations were used to derive possible mixture ratios for combustion tests. Due to the results, depending on the expansion ratio maximum I_{sp} can be reached in between ROF 5.5 to 8.75 for vacuum expansion. The combustion temperature at this mixture ratios are between 3000 and 3300 K, which will arouse the need for a proper cooling system in a later propulsion system. Furthermore the experimentally obtained I_{sp} values are assumed to be in between of the frozen and equilibrium calculations.

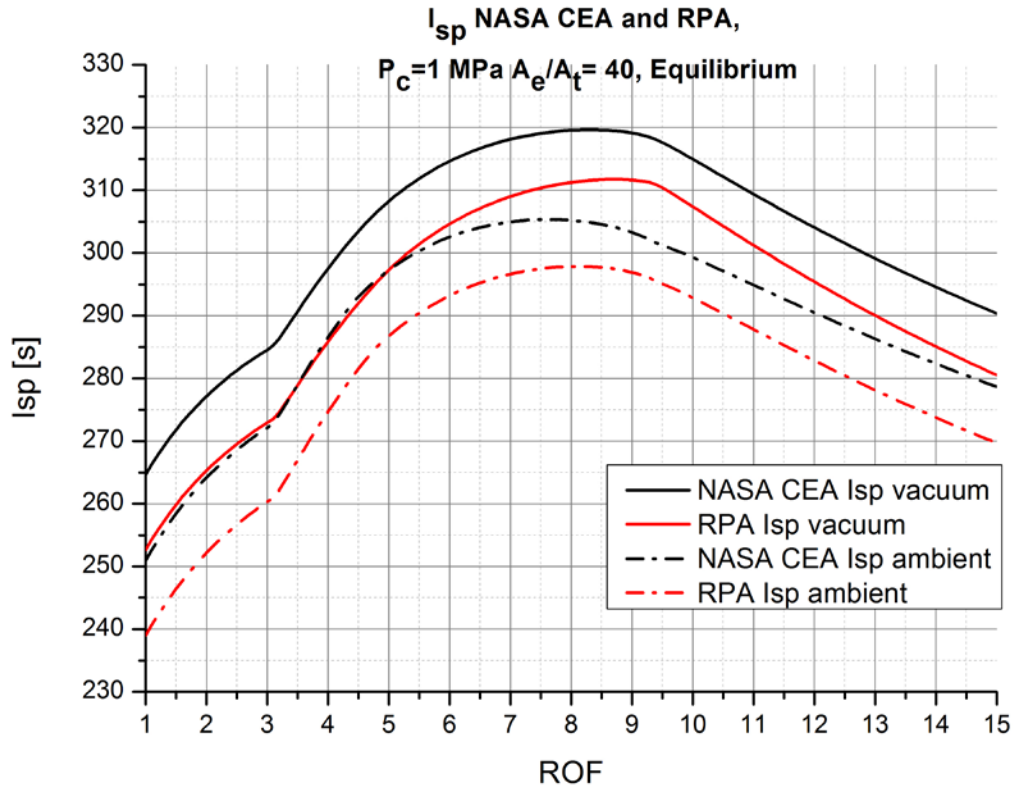

Figure 4: I_{sp} values for $\epsilon=40$ with equilibrium reactions

4 TEST SETUP

DLR's Institute of Space Propulsion set up a test bench and designed a demonstrator unit to analyze the ignition, combustion and injection process of the described nitrous oxide/ethene propellant.

4.1 Test Bench

The combustor and setup is situated inside a test container at the M11.5 at DLR Lampoldshausen. Up to now all tests were conducted with gaseous N_2O/C_2H_4 mixtures, thus general experience in handling the propellant mixture should be gained. The gas supply tanks are situated on the outside of the test container. Ignition of the propellant mixture can be



Figure 5: Test container at M11.5

carried out in different ways, for example a glow plug and a hydrogen/oxygen torch are mounted at the combustion chamber. To supply the combustor as well as the igniter the test setup is equipped with N_2O , C_2H_4 , N_2 , O_2 and H_2 feeding lines. The test bench's gas supply system, the valves, orifices, sensor positions and the check valves can be seen in Figure 6. Due to the gaseous state of the propellant, the mass flow and the mixture ratio is controlled and adjusted by calibrated orifices as well as pressure regulators upstream the tanks.

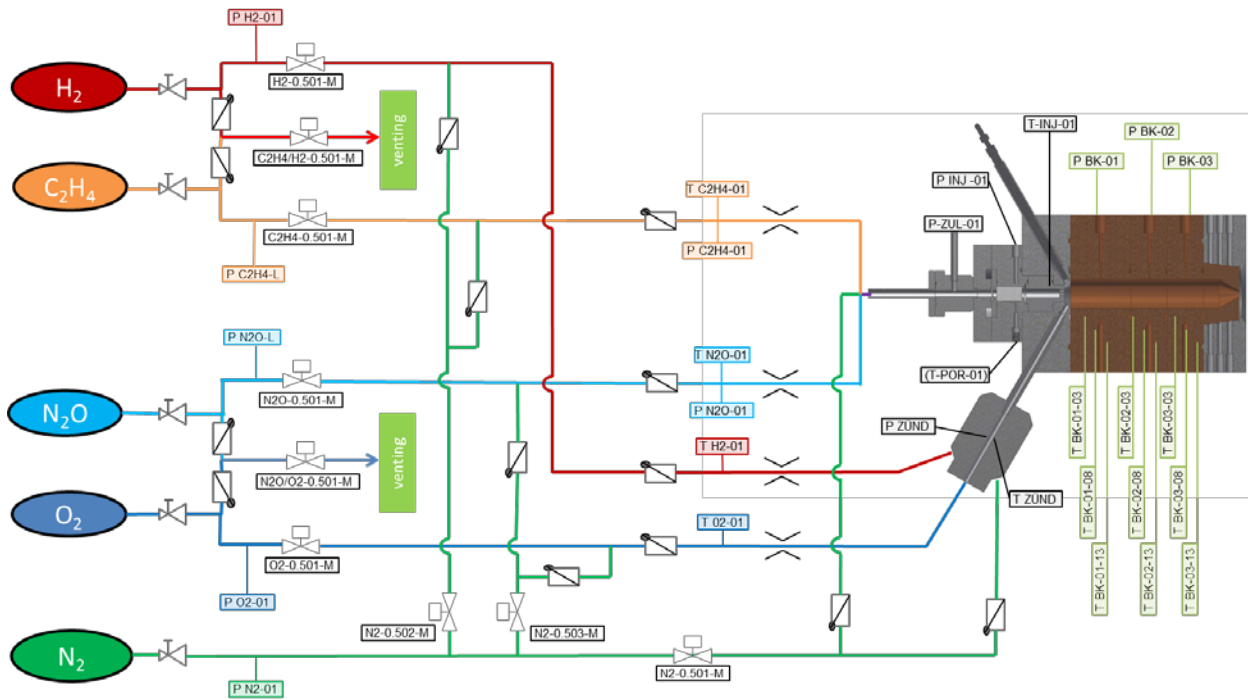

Figure 6: test bench gas supply system

4.2 Combustion Chamber, ignition and injection System

The combustion chamber consists of capacitive cooled CuCrZr (Elbrodur) segments. Additionally to establish longer combustion test times and to analyze the heat flux in future tests, water cooled segments were designed and manufactured [24]–[26]. During the test runs, thrust, supply pressure, chamber pressure, the temperature in the feeding lines as well as the temperatures in the chamber walls are measured. The chamber itself consists of several segments of different axial length. Up to now the tests have been performed with a combustor consisting of three capacitively cooled segments with an overall length of 110 mm. At each chamber segment, a maximum number of three thermocouples could be fixed at 3, 8 and 13 mm radial distance from inner combustion chamber wall. The currently used combustion chamber setup can be seen in Figure 7, the figure shows the two ignition systems, the currently used showerhead injector, the interchangeable nozzle and the chamber segments. The design of the injector head allows the use of different injection systems (e.g. porous injectors, different diameters). To avoid flashback upstream the injector, a porous cylinder is included in the feeding line. As the next paragraph shows, this flashback system has to be designed properly and additional flashback and pressure drop tests need to be conducted. Several truncated nozzles with different throat diameters were manufactured. As in the case of the chamber segments, the nozzles are also made of CuCrZr.

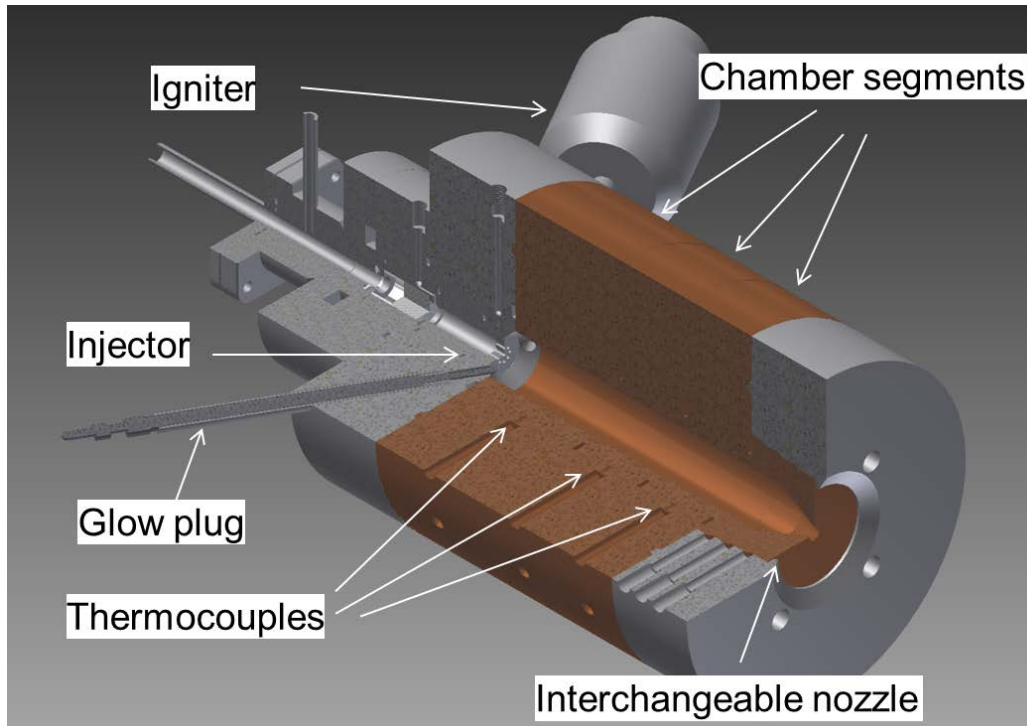

Figure 7: N_2O/C_2H_4 Combustor design

5 TEST RESULTS

Several combustion tests with the shown setup and the described combustor were conducted. During the tests different injection systems and two kinds of ignition methods were tested. The combustor was modified several times according to the test results. In this section the injection and ignition methods as well as the results will be described.

5.1 Impinging Injector

First tests were conducted with an impinging injector, originally designed for liquefied N_2O/C_2H_4 . The injector consists of 5×0.65 mm diameter holes; the centered injector is surrounded by 4 circular holes. The gas jets meet in a 12 mm distance from the faceplate. Due to the small holes and the gaseous state of the propellant, the pressure drop across the injector was quite high (about 1.5 MPa). This caused a pressure buildup in front of the injector which led to a pressure ratio smaller than 2 across the orifices in the upstream feeding lines. As a result the gases did not reach sonic velocity at the orifices. With this, the ROF value during the first hot runs could only be approximated. As a consequence of the high pressure drop across the injector, flashback occurred only during shutdown of the combustor. To avoid flashback at shutdown, the combustor was simultaneously flushed with nitrogen.

5.2 Test with Showerhead Injector

To adjust the pressure drop, enable higher propellant mass flow rates and determine the mixture ratio, a showerhead injector was designed and manufactured [27]. The showerhead consists of 9 coaxial

injectors holes with a diameter of 1.4mm. The calculated pressure drop of the injector should be in between 0.2-0.4 MPa for a mass flow of 25 g/s to 40 g/s. The injection speed achieved with this design should avoid flashback during stationary operation condition. During the conducted experiments the mass flow was slightly lower than the calculated values (in between 15 and 20 g/s). All performed combustion tests showed that the resulting pressure drop was not sufficient to avoid flashback. Successful combustion tests without flashback could only be conducted at a combustion pressure slightly above ambient pressure. It came clear that a sufficient gas injection speed to avoid flashback must be achieved. Furthermore the quenching diameter for N_2O/C_2H_4 flames has to be calculated and measured via experiments. To assure safe and reliable operation in future thrusters, both processes have to be studied in detail.

5.3 Ignition Methods

During most of the conducted combustion tests the N_2O/C_2H_4 mixture was ignited by the H_2/O_2 torch. The igniter worked very well and the mixture did light immediately. To avoid additional influence of the igniter, it was shut off 0.5s after the main valves of N_2O and C_2H_4 were opened.

Alternatively the implemented glow plug was used to ignite the propellant mixture thermally. Due to the glow plug's position at the edge of the combustion chamber and the resulting flow, ignition of N_2O and C_2H_4 did not take place instantly. It is assumed that a large part of the combustion chamber had to be filled with propellant to obtain an ignitable mixture at the glow plug's position. This resulted in a "hard" ignition of the mixture which was followed by a flashback across the injector.

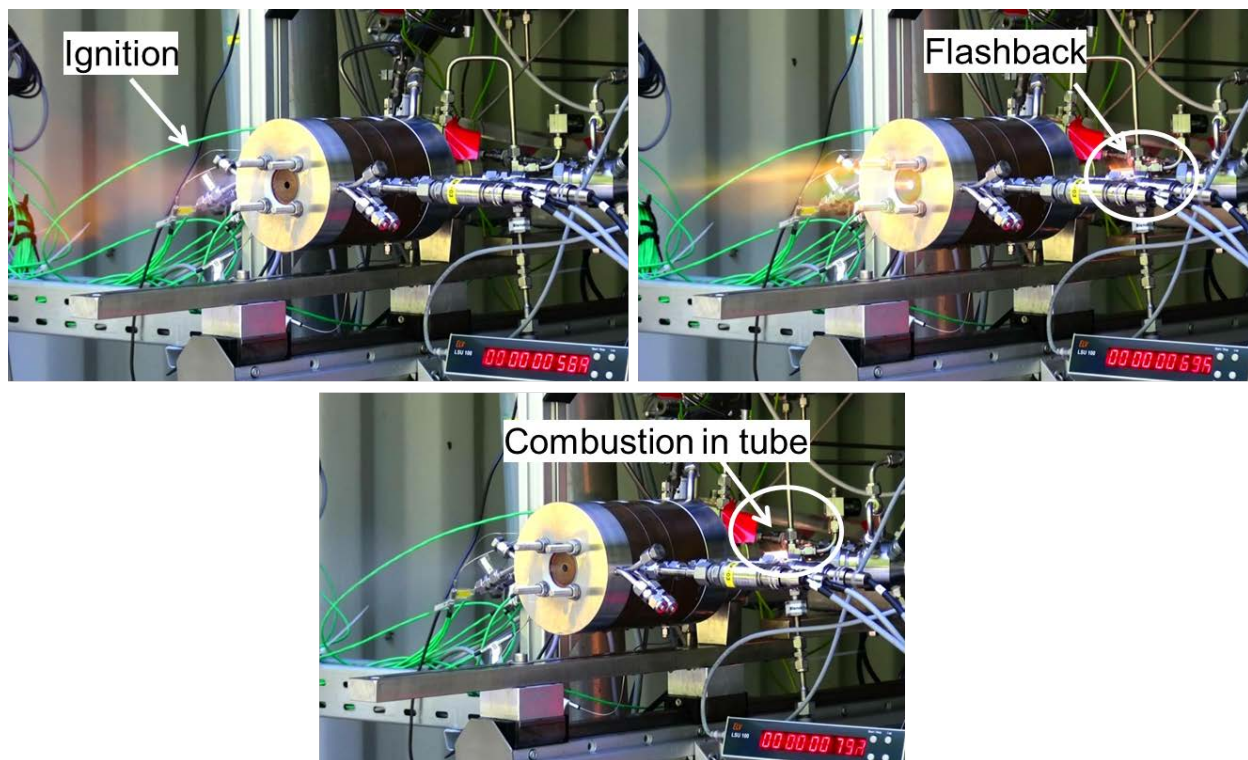

Figure 8: Images cut from test video while flashback occurs

5.4 Flashback Observation

In several combustion tests flashback during startup or shutdown of the combustor was observed. To investigate the occurrence of flashback and to avoid further propagation of the flame upstream the injector, a PMMA (Poly(methyl methacrylate)) tube was implemented in the feeding line. Above the tube a video camera was mounted to film the possible flame propagation upstream the injector. The videos were taken with a frame rate of 120 fps.



Figure 9: PMMA tube in feeding line before ignition (left) and after/during flashback (right)

Flashback occurring at startup of the combustor can be seen in the Figure 9. When the flame propagated upstream the injector two different effects were observed: Either an explosion of the PMMA tube (in combination with a distinct pressure peak), or combustion in the tube (without a distinct pressure peak). Up to now the conditions which cause the first or second effect are not known. To analyze the influences, further tests are planned.

6 CONCLUSION & OUTLOOK

To analyze the performance of a nitrous oxide/ethane (N_2O/C_2H) premixed propellant, a set of calculations with RPA and NASA CEA were conducted. The corresponding performance parameters were estimated and a test bench as well as combustion chamber were designed and manufactured. During the first test runs, different injection systems were tested. Due to the test results the test bench was modified several times and equipped with a PMMA tube to observe flashback visually. The conducted combustion tests showed that the development of an appropriate flashback arrestor is necessary. To analyze the different effects resulting in backward flame propagation, a separate test setup will be set up. With this setup the factors influencing flashback will be investigated. Additionally new improved injectors need to be designed to conduct further combustion tests.

7 ACKNOWLEDGEMENT

The authors would like to thank the M11 test bench team, Ingo Dörr, Hagen Friedrich and Jan Buddenberg for helping conducting and preparing the combustion test. Furthermore many thanks go to Philip Reese, and Manuel Wößner who put great effort in analyzing, preparing and discussing the test results, conducted pretests and modified the setup. Special thanks go to Andreas Gernoth for his

continuous support in discussing the results, for his experimental advice as well as for reviewing this paper.

8 REFERENCES

- [1] A. Ponomarenko, "RPA-Tool for Rocket Propulsion Analysis," *Space Propulsion Conference, Cologne, Germany*, 2014.
- [2] B. J. McBride and S. Gordon, *Computer Program for Calculation of Complex Chemical Equilibrium Compositions and Applications II. User's Manual and Program Description*. National Aeronautics and Space Administration Lewis Research Center Cleveland, Ohio 44135-3191: NASA, 1996.
- [3] R. L. Sackheim and R. K. Masse, "Green propulsion advancement - Challenging the maturity of monopropellant Hydrazine," *5th European Conference for Aeronautics and Space Sciences*, 2013.
- [4] J. D. Clark, *Ignition! An Informal History of Liquid Rocket Propellants*. RUTGERS UNIVERSITY PRESS New Brunswick, New Jersey, 1972.
- [5] F. Valencia-Bel and M. Smith, "Replacement of Conventional Spacecraft Propellants with Green Propellants," *Space Propulsion Conference Bordeaux, France*, 2012.
- [6] Space.com, "At Solar System's Edge, Old Voyager 1 Probe Performs New 'Acrobatics,'" 03-Oct-2011. [Online]. Available: <http://www.space.com/11087-nasa-voyager-1-acrobatics-solar-system.html>.
- [7] E. European Chemicals Agency, "Candidate List of substances of very high concern for Authorisation," *Candidate List of substances of very high concern for Authorisation*. [Online]. Available: <http://echa.europa.eu/en/candidate-list-table>. [Accessed: 24-Jun-2015].
- [8] A. S. Gohardani, J. Stanojev, Alain Demairé, K. Anflo, M. Persson, N. Wingborg, and C. Nilsson, "Green space propulsion: Opportunities and prospects," *Progress in Aerospace Sciences*, vol. 71, pp. 128–149, 2014.
- [9] R. A. Spores, R. Masse, S. Kimbrel, and C. McLean, "GPIM AF-M315E Propulsion System," *50th AIAA/ASME/SAE/ASEE Joint Propulsion Conference & Exhibit AIAA 2014-28-30 July 2013, Cleveland, Ohio*, 2013.
- [10] N. Wingborg, K. Anflo, T.A. Grönland, "Development and testing of ADN-based monopropellants in small rocket engines," *36th AIAA/ASME/SAE/ASEE Joint propulsion Conference, Las Vegas, Nevada, USA*, 2000.
- [11] N. Wingborg, C. Eldsäter, and H. Skifs, "Formulation and characterization of ADN-based liquid monopropellants," *2nd Int. Conference on green propellants for space propulsion, Cagliari, Italy*, 2004.
- [12] M. Wurdak, F. Strauss, L. Werling, H. K. Ciezki, D. Greuel, R. Lechler, N. Wingborg, D. Hassan, and C. Scharlemann, "Determination of fluid properties of the green propellant FLP-106 and related material and component testing with regard to applications in space missions," *Space Propulsion Conference, Bordeaux, France*, 2012.
- [13] G. Mungas, D. J. Fisher, C. Mungas, and B. Carryer, "Nitrous Oxide Fuel Blende Monopropellant" Patent No. US20090133788 A1, 28-May-2009.
- [14] G. Mungas, M. Vozoff, and B. Rishikof, "NOFBX™: A new non-toxic, 'Green' propulsion technology with high performance and low cost," *63rd International Astronautical Congress, Naples, Italy*, pp. 8078–8087, 2012.
- [15] V. Casson and G. Maschio, "Screening Analysis for Hazard Assessment of Peroxides Decomposition," *Industrial & Engineering Chemistry Research*, 2012.
- [16] M. Ventura, Eric Wernimont, S. Heister, and S. Yuan, "Rocket Grade Hydrogen Peroxide (RGHP) for use in Propulsion and Power Devices - Historical Discussion of Hazards," *43rd AIAA/ASME/SAE/ASEE Joint Propulsion Conference & Exhibit 8 - 11 July 2007, Cincinnati, OH, USA*, 2007.

- [17] D. Kajon, F. Masson, T. Wagner, D. Welberg, T. Büchner da Costa, and J. Mansouri, "Development of an Attitude Control and Propellant Settling System for the aA5ME Upper Stage," *Space Propulsion Conference, Cologne, Germany, 2014*.
- [18] L. Werling, B. Hochheimer, A. Baral, H. K. Ciezki, and S. Schlechtriem, "Experimental and Numerical Analysis of the Heat Flux occurring in a Nitrous Oxide/Ethene Green Propellant Combustion Demonstrator," presented at the 51st AIAA/SAE/ASEE Joint Propulsion Conference, Orlando, Florida, USA.
- [19] K. Neff, P. King, K. Anflo, and R. Möllerberg, "High performance green propellant for satellite applications," *45th AIAA/ASME/SAE/ASEE Joint Propulsion Conference & Exhibit, Denver, Colorado, USA, 2009*.
- [20] M. Persson, K. Anflo, A. Dinardi, and J.-M. Bahu, "A family of thrusters for ADN-based monopropellant LMP-103S," *48th AIAA/ASME/SAE/ASEE Joint Propulsion Conference & Exhibit, Atlanta, Georgia, USA, 2012*.
- [21] N. Wingborg, J. Martin, and B. Lars, "Initial development of a laboratory rocket thruster for ADN-based liquid monopropellants," Technical report, FOI-Swedish Defence Research Agency, FOI-R-2123-SE, ISSN 1650-1942, 2006.
- [22] C. Hendrich, A. Gernoth, N. Wingborg, C. Scharlemann, H. Ciezki, and S. Schlechtriem, "Influence of water content in an ADN based liquid monopropellant on performance characteristics," *Space Propulsion Conference, Cologne, Germany, 2014*.
- [23] A. Cervone, L. Torre, d'Agostino Luca, A. J. Musker, G. T. Roberts, C. Bramanti, and G. Saccoccia, "Development of Hydrogen Peroxide Monopropellant Rockets," *42nd AIAA/ASME/SAE/ASEE Joint Propulsion Conference & Exhibit 9 - 12 July 2006, Sacramento, California, USA, 2006*.
- [24] B. Hochheimer, *Numerical analysis of the flow behavior in cooling channels of a combustion chamber for Green Propellants*. Bachelor thesis, University of Stuttgart, Germany, 2015.
- [25] A. Baral, *Auslegung und Konstruktion einer gekühlten Brennkammer für fortschrittliche Satellitentreibstoffe*. Student research project, Bundeswehr University Munich, Germany, 2014.
- [26] L. Werling, A. Gernoth, and S. Schlechtriem, "Investigation of the Combustion and Ignition Process of a Nitrous Oxide/Ethene Fuel Blend," *Space Propulsion Conference, Cologne, Germany, 2014*.
- [27] N. Perakis, B. Hochheimer, L. Werling, A. Gernoth, and S. Schlechtriem, "Development of an experimental demonstrator unit using Nitrous Oxide/Ethylene Premixed Bipropellant for satellite applications," *Meet the Space Conference, Krakow, Poland, 2014*.